

### Introduction

This ARRISCRAFT • NOTE discusses the proper placement and construction of movement joints in clipped or anchored thin quarried or manufactured calcium silicate unit veneer.

There are basically two distinct types of movement joints used in construction: *elastic* and *inelastic*. Both of these joint types are designed to perform a specific function, and they should not be used interchangeably.

*Inelastic* movement joints include *construction joints* and *control joints*.

- *Construction joints* are used wherever the construction work is to be interrupted. They are usually located where they will least impair the strength of the structure.
- *Control joints* are largely used in concrete unit masonry construction to create a plane of weakness. When used in conjunction with joint reinforcement, they control the location of cracks due to volume changes resulting from shrinkage and creep. They are not generally sufficient to accommodate net material expansion.

*Elastic* movement joints include *building expansion joints* and *expansion joints*.

- *Building expansion joints* are used to separate a building into discrete sections so that stresses developed in one section will not affect the integrity of the entire structure.
- *Expansion joints* are used mainly in clay brick, calcium silicate, or stone masonry construction. They are used to segment the veneer to prevent cracking due to changes in temperature, moisture expansion, elastic deformation due to loads, and creep. They may be horizontal or vertical.

It is the elastic-type movement joint that is most appropriate for use in a clipped or anchored thin veneer application, and requirements for this type of joint will form the basis of the following discussion.

### Movement Joints in Clipped or Anchored Thin Veneer Applications

Movement joints can be constructed in a variety of different ways to fulfill these requirements. They may include waterstops and pre-moulded foam or neoprene pads as barriers to keep mortar or other debris from clogging the joint. These materials must be highly compressible and elastic in nature in order to accommodate the expansion and contraction of the

veneer materials. As such, the use of fiberboard or other similar materials are not recommended for use in movement joints.

No solid materials should bridge the movement joint as they would restrict movement and not allow the movement joint to perform its intended function.

### Materials for Movement Joints

A good quality backer rod and joint sealant should be used to seal the exterior of the movement joint against moisture and air penetration. The sealant material should be selected by the designer to be highly elastic, resistant to weathering and ultraviolet radiation, and compatible with the clipped or anchored thin veneer materials, including any adjacent materials such as flashing membranes or metal elements.

The size of the movement joint should be considered when selecting the type of joint sealant. The sealant must be able to span the joint and accommodate the anticipated movements of all materials. As a rule of thumb, joint sealants used in movement joints should typically have a width-to-depth ratio of 2:1 in order to ensure adequate protection against moisture and air penetration (Figure 1).

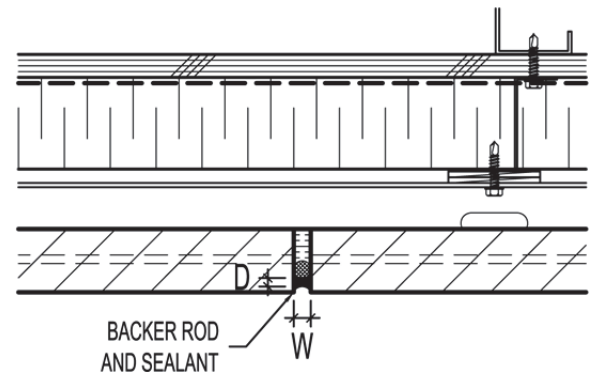

**Figure 1**

The inclusion of a good quality backer rod is important to proper joint design. The backer rod is used to:

- act as a bond breaker, forcing the sealant into two-point adhesion. It should be noted that sealant may fail prematurely when put into three-point adhesion as this subjects the sealant to shear stress in addition to tension/compression;
- achieve the required 2:1 width-to-depth ratio of the sealant; and
- provide a firm surface against which tooling can be done. Proper tooling optimizes the joint's weather resistance and ensures better adhesion of the sealant.

The backer rod allows the sealant to be tooled into an hourglass shape, providing maximum flexibility.

For further information refer to ARRISCRAFT•NOTE (Vol. IV, No. 4) Important Criteria for Sealant and Backer Rod Selection.

### Sizing of Movement Joints

Vertical movement joint frequency and size should be designed to accommodate the anticipated movement of the veneer materials. The joints must be of sufficient size to contend with the anticipated movements, without being so large as to be difficult to weather-proof. Typically, joints sized to resemble a mortar joint will be adequate to accommodate the anticipated movements and still be easily sealed against the elements.

The design of horizontal movement joints depends largely upon the anticipated loads and resulting deflections which are expected to occur at their particular locations.

### Placement of Movement Joints

When using a clipped or anchored thin veneer application there are two distinct installation types that may be used: open rainscreen and sealed rainscreen. The type of system used will determine the placement and frequency of movement joints.

A sealed rainscreen system consists of soft joints constructed in the horizontal and vertical joints between thin-clad veneer units. These soft joints would be constructed from a good quality backer rod and joint sealant, effectively creating movement joints at these locations. As a result, the only additional differential movement consideration that may arise would be at floor slab deflection joints. Horizontal movement joints should be placed at these locations (Figure 2).

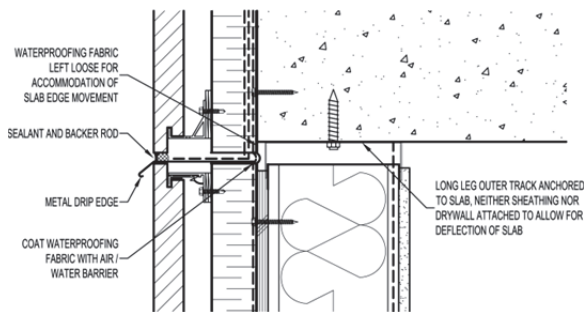

Figure 2

Open rainscreen systems using semi-rigid vertical water blockers require additional considerations for placement of movement joints. The actual location and frequency of movement joints in an open rainscreen system is dependent upon the configuration of the structure as well as the expected amount of movement dictated by micro-environmental factors. They need to be designed as part of the building envelope by the designer and their

location and extent must be clearly indicated on the building elevations.

As a general rule of thumb, movement joints should be located at the following locations:

- at changes in wall direction, such as building corners;
- at wall openings, such as windows and doors;
- at changes in building height, such as building junctions;
- at major changes in thickness of wall, such as pilasters;
- at periodic lengths of continuous wall;
- at changes of building materials; and
- at horizontal deflection joints.

*Corners:* Walls perpendicular to one another will expand towards their juncture, typically causing distress at the first head joint on either side of the corner. Movement joints should be placed near corners to alleviate this stress (Figure 3).

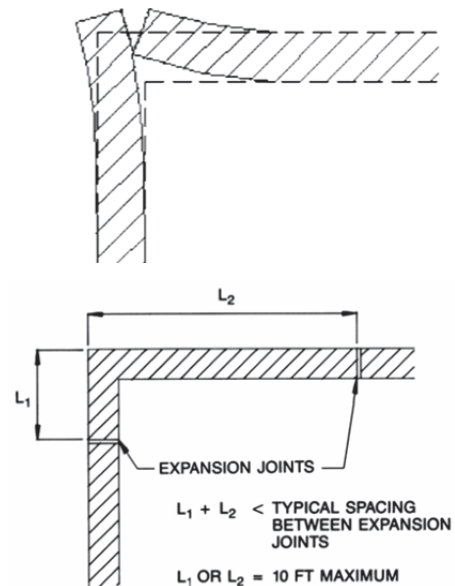
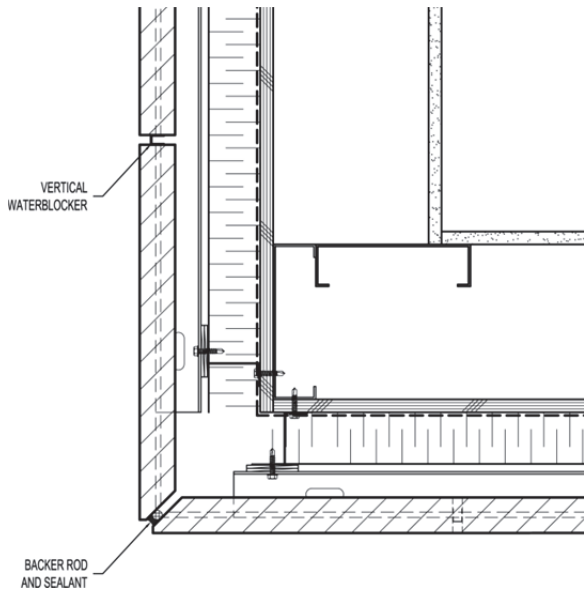

Figure 3

When corners are constructed with quirk mitered joints, a movement joint may be placed in the continuous vertical joint created by the miter (Figure 4).



**Figure 4**

*Intersections, Offsets and Setbacks:* Parallel walls expand towards the offset, rotating the short clipped or anchored thin veneer leg or causing cracks within the offset. Movement joints should be placed at the offset to allow the parallel walls to expand (Figure 5). Intersecting walls not required to be bonded should also include a movement joint at the intersection.

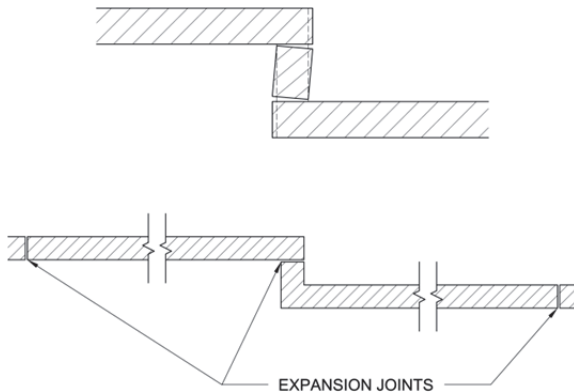

**Figure 5**

*Wall Openings:* More movement will tend to occur above and below openings due to the change in the wall's mass. The differential movement between areas of different wall mass may cause cracks to emanate from the corners of the openings. As these openings also tend to "weaken" the wall, they act as naturally occurring movement joints.

*Junctions/Changes in Wall Height:* Just as with wall openings, large variations in wall height should include a movement joint at the juncture to accommodate the differential movement tendencies of the two different wall masses.

*Periodic Spacing within Continuous Lengths of Wall:* Large expanses of clipped or anchored thin veneer will, by virtue of the aggregate sum of their individual

dimensional changes, experience significant strain over the length of the wall. To alleviate this effect, continuous vertical movement joints should be incorporated along the length of the wall, generally at a spacing of between 20-25 feet (6-7.6 metres).

*Changes in Building Materials:* Different materials will react differently to the effects of thermal and moisture change. For example, curtain wall systems and clipped or anchored thin veneer systems expand and contract at differing rates. The effects of such differential movement need to be accounted for and accommodated by the inclusion of a properly sized movement joint.

It is important that movement joints placed within veneer walls be continuous through all of the veneer materials. Movement joints should only terminate at an intersecting horizontal movement joint or the top or bottom of the wall.

### **Other Considerations Affecting Placement**

Placement of movement joints may also be influenced by additional factors.

Parapets are exposed on three sides to extremes of moisture and temperature. This may cause substantially different movement from that of the wall below. Placing additional movement joints at these locations may be good practice.

Wherever spandrel wall sections are supported by a beam or floor slab, additional vertical movement joints may be required.

Allowance for differential movement between the building veneer and structural elements (such as steel beams, anchor points for signage, or utilities) should always be provided.

### **Aesthetic Considerations**

Movement joint design and placement can impact the overall aesthetics of the building façade.

Following are considerations that can minimize their visual impact:

- Pigment vertical movement joints to match the color of the adjacent veneer units (Figure 6). When adjacent unit color changes up the height of the joint, change the sealant color to match (Figure 7).
- Pigment horizontal movement joints to match the color of the mortar joints.
- Silt the movement joint to create a mortar-like appearance (Figure 8).

Alternatively, movement joints may also be accentuated as part of the architectural design of the building face (Figures 9 and 10). Their placement in the wall can create symmetry (Figure 11) and create aesthetically pleasing façades.



**Figure 6: Sealant colored to match color of adjacent veneer units.**



**Figure 9: Movement joint placed at continuous notch in veneer.**



**Figure 7: Change sealant color within the vertical joint to match changing unit colors up the height of the wall.**



**Figure 10: Movement joint integrated into design.**

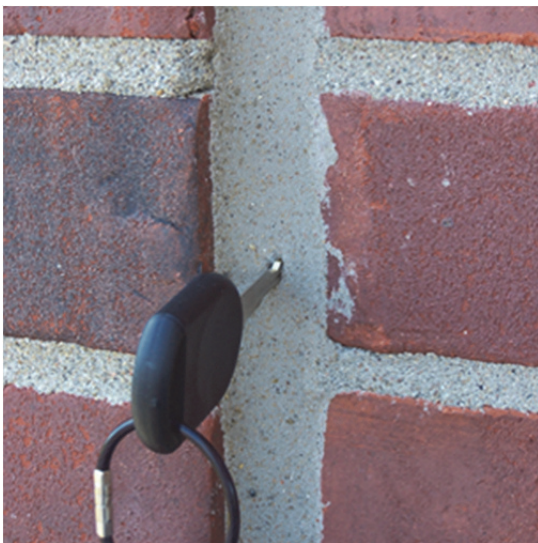

**Figure 8: Silt the sealant surface to emulate mortar.**

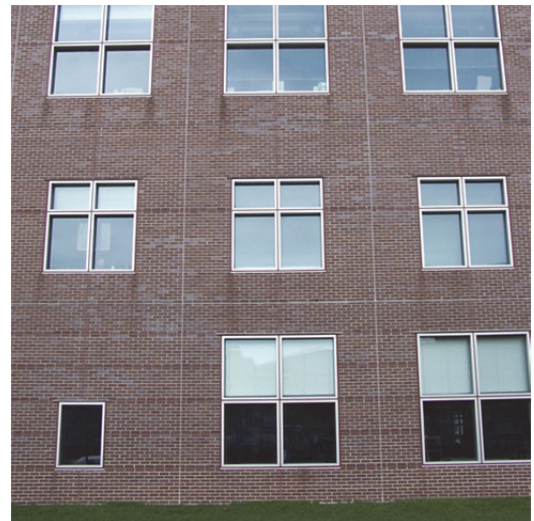

**Figure 11: Placement of movement joints creates wall symmetry.**

## Summary

This ARRISCRAFT•NOTE describes the different kinds of joints found in building construction and discusses the appropriate design and use of movement joints in clipped or anchored thin veneer construction.

Movement joints are used in clipped or anchored thin veneer construction to allow for the differential movement generated by materials as they react to their own properties, environmental conditions and loads. In general, vertical movement joints should be used to break the clipped or anchored thin veneer into rectangular elements that have the same support conditions, the same climatic exposure and the same through-wall construction.

The information and suggestions contained herein are based upon the available data and information published by the listed references and the experience of Arriscraft architectural and engineering staff. More detailed information may be found by referring to any of the related references listed below.

The information contained herein must be used in conjunction with good technical judgment and a competent understanding of curtain wall construction. Final decisions on the use of the information contained in this ARRISCRAFT•NOTE are not within the purview of Arriscraft and must rest with the project designer or owner, or both. It remains the sole responsibility of the designer to properly design the project, ensure all architectural and engineering principles are properly applied throughout, and ensure that any suggestions made by Arriscraft are appropriate in the instance and are properly incorporated through the project.

## Related References

1. Brick Industry Association, Technical Notes on Brick construction 18, Volume Changes – Analysis and Effects of Movement, October 2006.
2. Brick Industry Association, Technical Notes on Brick Construction 18A, Accommodating Expansion of Brickwork, November 2006.
3. Canada Mortgage and Housing Corporation, Best Practice Guide, Brick Veneer Concrete Masonry Unit Backing, 1997.
4. Drysdale, Hamid, Baker; Masonry Structures – Behavior and Design – Second Edition, The Masonry Society, 1999.
5. Ontario Masonry Industry Promotion Fund, 4C 8202, Movement Control, February 1982.
6. Ontario Masonry Industry Promotion Fund, 4C 8504, Restraints and Movements in Masonry Walls, April 1985.
7. TCNA Handbook for Ceramic, Glass, and Stone Tile Installation, 2013.

## Arriscraft

P.O. Box 3190  
875 Speedsville Road  
Cambridge, Ontario  
Canada N3H 4S8

Toll Free: 1-800-265-8123  
Telephone: (519) 653-3275  
Fax: (519) 653-1337  
E-mail: solutions@arriscraft.com  
Web: www.arriscraft.com